

DIN EN 22 568

HOBBOY NO/CS/WS
code 210 XXX

STANDARD HSS
code 240 XXX

STANDARD HSS
code 250 XXX

STANDARD HSS
code 270 XXX

STANDARD HSS
code 280 XXX

Závitové kruhové čelisti Circular dies Schneideisen Плашки

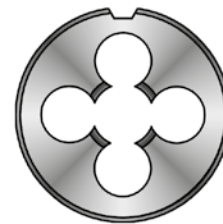
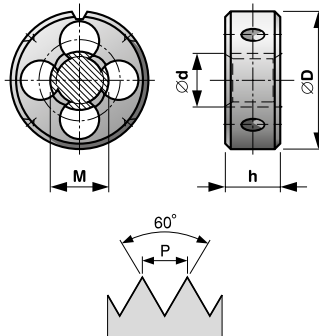

M Metrický závit ISO DIN 13
Standard metric thread ISO DIN 13
Metrische Regelgewinde ISO DIN 13
Метрическая резьба ISO DIN 13

Licování: 6g (6h, 6e - dle požadavku zákazníka) / Tolerance: 6g
(6h, 6e - on request) / Toleranz: 6g (6h, 6e - nach dem Anspruch) /
Подгонка: 6g (6h, 6e - по заказу)



1,5P

	P	ØD	h	S		code ^{x)}
M 1	0,25	16	5	3	0,97	XXX 010
M 1,1	0,25	16	5	3	1,07	XXX 011
M 1,2	0,25	16	5	3	1,17	XXX 012
M 1,4	0,3	16	5	3	1,36	XXX 014
M 1,6	0,35	16	5	3	1,54	XXX 016
M 1,8	0,35	16	5	3	1,74	XXX 018
M 2	0,4	16	5	3	1,93	XXX 020
M 2,2	0,45	16	5	3	2,13	XXX 022
M 2,5	0,45	16	5	3	2,43	XXX 025
M 3	0,5	20	5	3	2,92	XXX 030
M 3,5	0,6	20	5	3	3,41	XXX 035
M 4	0,7	20	5	3	3,91	XXX 040
M 4,5	0,75	20	5	3	4,41	XXX 045
M 5	0,8	20	7	4	4,90	XXX 050
M 6	1	20	7	4	5,88	XXX 060
M 7	1	25	9	4	6,88	XXX 070
M 8	1,25	25	9	4	7,87	XXX 080
M 9	1,25	25	9	4	8,87	XXX 090
M 10	1,5	30	11	4	9,85	XXX 100
M 11	1,5	30	11	5	10,85	XXX 110
M 12	1,75	38	14	4	11,83	XXX 120
M 14	2	38	14	5	13,82	XXX 140
M 16	2	45	18	5	15,82	XXX 160
M 18	2,5	45	18	5	17,79	XXX 180
M 20	2,5	45	18	6	19,79	XXX 200
M 22	2,5	55	22	5	21,79	XXX 220
M 24	3	55	22	6	23,76	XXX 240
M 27	3	65	25	6	26,76	XXX 270
M 30	3,5	65	25	7	29,73	XXX 300
M 33	3,5	65	25	8	32,73	XXX 330
M 36	4	65	25	9	35,70	XXX 360
M 39	4	75	30	8	38,70	XXX 390
M 42	4,5	75	30	9	41,69	XXX 420
M 45	4,5	90	36	8	44,69	XXX 450
M 48	5	90	36	8	47,66	XXX 480
M 52	5	90	36	9	51,66	XXX 520
M 56	5,5	105	36	8	55,65	XXX 560
M 60	5,5	105	36	8	59,65	XXX 600
M 64	6	120	36	8	63,62	XXX 640
M 68	6	120	36	8	67,62	XXX 680

x) 210 XXX - NO / CS / WS do M 30 / to M 30 / bis M 30 / до M 30

x) 240 XXX - HSS pravý závit / right hand thread / rechts Gewinde / правая резьба

x) 250 XXX - HSS LH závit / LH thread / LH Gewinde / LH резьба

x) 270 XXX - HSS s lamačem třísek / with spiral point / mit Schälanschnitt / с ломателем стружек

x) 280 XXX - HSS LH s lamačem třísek / LH with spiral point / LH mit Schälanschnitt / LH с ломателем стружек



**BUČOVICE
TOOLS a.s.**

Materiál: NO; HSS
- dle požadavku
Provedení: závit lapovaný
do M 26
Závit: pravý, levý

Material: CS-carbon steel;
HSS - on request
Execution: lapped thread
to M 26
Thread: right-hand, left-hand

Werkstoff: WS-Werkzeugstahl;
HSS - nach dem Anspruch
Ausführung: geläpftes
Gewinde bis M 26
Gewinde: rechts, links

Материал: NO-инструментальная сталь; HSS - по заказу
Изготовлено: резьба шлифованная до M 26
Резьба: правая, левая

DIN EN 22 568

HOBBY NO/CS/WS
code 210 XXX

STANDARD HSS
code 240 XXX

STANDARD HSS
code 250 XXX

STANDARD HSS
code 270 XXX

STANDARD HSS
code 280 XXX

Závitové kruhové čelisti Circular dies Schneideisen Плашки

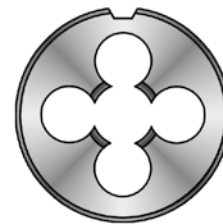
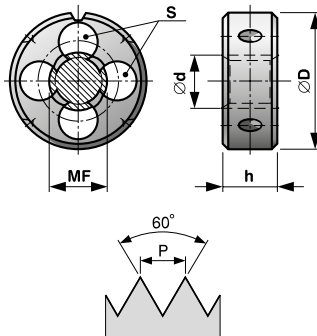

Jemný metrický závit ISO DIN 13
Fine metric thread ISO DIN 13
Metrische Feingewinde ISO DIN 13
Мелкая метрическая резьба ISO DIN 13

Licování: 6g (6h, 6e - dle požadavku zákazníka) / Tolerance: 6g
(6h, 6e - on request) / Toleranz: 6g (6h, 6e - nach dem Anspruch) /
Подгонка: 6g (6h, 6e - по заказу)



1,5P

MF

	P	ØD	h	S		code ^{x)}
MF 1,7	0,35	16	5	3	1,67	XXX 017
MF 2,3	0,4	16	5	3	2,26	XXX 023
MF 2,3	0,45	16	5	3	2,26	XXX 024
MF 2,5	0,35	16	5	3	2,44	XXX 026
MF 2,6	0,45	16	5	3	2,56	XXX 027
MF 3	0,35	20	5	3	2,94	XXX 031
MF 3,5	0,35	20	5	3	3,44	XXX 036
MF 4	0,5	20	5	3	3,93	XXX 041
MF 4,5	0,5	20	5	3	4,43	XXX 046
MF 5	0,5	20	5	4	4,93	XXX 051
MF 5,5	0,5	20	5	4	5,43	XXX 056
MF 6	0,75	20	7	4	5,91	XXX 061
MF 7	0,75	25	9	4	6,90	XXX 071
MF 8	1	25	9	4	7,88	XXX 081
MF 8	0,75	25	9	4	7,90	XXX 082
MF 9	1	25	9	4	8,88	XXX 091
MF 9	0,75	25	9	4	8,90	XXX 092
MF 10	1,25	30	11	4	9,86	XXX 101
MF 10	1	30	11	4	9,88	XXX 102
MF 10	0,75	30	11	4	9,90	XXX 103
MF 11	1	30	11	5	10,88	XXX 111
MF 11	0,75	30	11	5	10,91	XXX 112
MF 12	1,5	38	10	4	11,85	XXX 121
MF 12	1,25	38	10	4	11,86	XXX 122
MF 12	1	38	10	4	11,88	XXX 123
MF 14	1,5	38	10	5	13,85	XXX 141
MF 14	1,25	38	10	5	13,86	XXX 142
MF 14	1	38	10	5	13,88	XXX 143
MF 15	1,5	38	10	5	14,85	XXX 151
MF 15	1	38	10	5	14,88	XXX 152
MF 16	1,5	45	14	5	15,85	XXX 161
MF 16	1	45	14	5	15,88	XXX 162
MF 17	1,5	45	14	5	16,85	XXX 171
MF 17	1	45	14	5	16,38	XXX 172
MF 18	2	45	14	5	17,82	XXX 181
MF 18	1,5	45	14	5	17,85	XXX 182
MF 18	1	45	14	5	17,88	XXX 183
MF 20	2	45	14	6	19,82	XXX 201
MF 20	1,5	45	14	6	19,85	XXX 202
MF 20	1	45	14	6	19,88	XXX 203
MF 22	2	55	16	5	21,82	XXX 221
MF 22	1,5	55	16	5	21,85	XXX 222
MF 22	1	55	16	5	21,88	XXX 223
MF 24	2	55	16	6	23,82	XXX 241
MF 24	1,5	55	16	6	23,85	XXX 242
MF 24	1	55	16	6	23,88	XXX 243
MF 25	1,5	55	16	6	24,85	XXX 251
MF 26	1,5	55	16	6	25,85	XXX 261
MF 27	2	65	18	6	26,82	XXX 271
MF 27	1,5	65	18	6	26,85	XXX 272
MF 27	1	65	18	6	26,88	XXX 273
MF 28	2	65	18	6	27,82	XXX 281
MF 28	1,5	65	18	6	27,85	XXX 282
MF 30	2	65	18	6	29,82	XXX 301
MF 30	1,5	65	18	6	29,85	XXX 302
MF 30	1	65	18	6	29,88	XXX 303
MF 32	1,5	65	18	7	31,85	XXX 321
MF 33	2	65	18	8	32,82	XXX 331
MF 33	1,5	65	18	8	32,85	XXX 332
MF 35	1,5	65	18	9	34,85	XXX 351

Materiál: NO: HSS
Provedení: závit lapovaný
do M 26
Závit: pravý, levý

Material: CS-carbon steel;
HSS
Execution: lapped thread
to M 26
Thread: right-hand, left-hand

Werkstoff: WS-Werkzeugstahl;
HSS
Ausführung: geläpftes
Gewinde bis M 26
Gewinde: rechts, links

Материал: NO-инструмен-
тальная сталь: HSS
Изготовлено: резьба
шлифованная до M 26
Резьба: правая, левая

**BUČOVICE
TOOLS a.s.**



MF 35

DIN EN 22 568

HOBBY NO/CS/WS
code 210 XXX

STANDARD HSS
code 240 XXX

STANDARD HSS
code 250 XXX

STANDARD HSS
code 270 XXX

STANDARD HSS
code 280 XXX

Závitové kruhové čelisti Circular dies Schneideisen Плашки

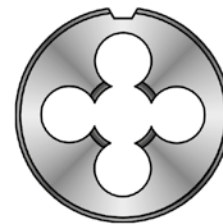
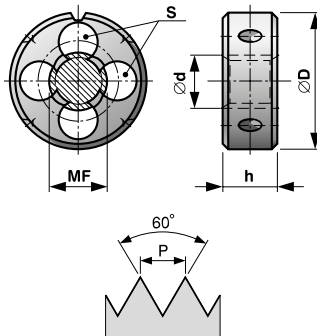

Jemný metrický závit ISO DIN 13
Fine metric thread ISO DIN 13
Metrische Feingewinde ISO DIN 13
Мелкая метрическая резьба ISO DIN 13

Licování: 6g (6h, 6e - dle požadavku zákazníka) / Tolerance: 6g
(6h, 6e - on request) / Toleranz: 6g (6h, 6e - nach dem Anspruch) /
Подгонка: 6g (6h, 6e - по заказу)



1,5P

MF

	P	ØD	h	S		code ^{x)}
MF 36	3	65	25	9	35,76	XXX 361
MF 36	2	65	18	9	35,82	XXX 362
MF 36	1,5	65	18	9	35,85	XXX 363
MF 39	3	75	30	8	38,76	XXX 391
MF 39	2	75	20	8	38,82	XXX 392
MF 39	1,5	75	20	8	38,85	XXX 393
MF 40	1,5	75	20	8	39,85	XXX 401
MF 42	3	75	30	9	41,76	XXX 421
MF 42	2	75	20	9	41,82	XXX 422
MF 42	1,5	75	20	9	41,85	XXX 423
MF 45	3	90	36	8	44,76	XXX 451
MF 45	2	90	22	8	44,82	XXX 452
MF 45	1,5	90	22	8	44,85	XXX 453
MF 48	3	90	36	8	47,76	XXX 481
MF 48	2	90	22	8	47,82	XXX 482
MF 48	1,5	90	22	8	47,85	XXX 483
MF 50	1,5	90	22	9	49,85	XXX 501
MF 52	3	90	36	9	51,76	XXX 521
MF 52	2	90	22	9	51,82	XXX 522
MF 52	1,5	90	22	9	51,85	XXX 523
MF 55	4	105	22	8	54,73	XXX 551
MF 55	3	105	22	8	54,76	XXX 552
MF 55	2	105	36	8	54,82	XXX 553
MF 55	1,5	105	36	8	54,85	XXX 554
MF 56	4	105	36	8	55,73	XXX 561
MF 56	3	105	36	8	55,76	XXX 562
MF 56	2	105	22	8	55,82	XXX 563
MF 56	1,5	105	22	8	55,85	XXX 564

x) 210 XXX - NO / CS / WS do M 30 / to M 30 / bis M 30 / до M 30

x) 240 XXX - HSS pravý závit / right hand thread / rechts Gewinde / правая резьба

x) 250 XXX - HSS LH závit / LH thread / LH Gewinde / LH резьба

x) 270 XXX - HSS s lamačem třísek / with spiral point / mit Schälanschnitt / с лопателем стружек

x) 280 XXX - HSS LH s lamačem třísek / LH with spiral point / LH mit Schälanschnitt / LH с лопателем стружек



**BUČOVICE
TOOLS a.s.**

Materiál: NO; HSS
Provedení: závit lapovaný
do M 26
Závit: pravý; levý

Material: CS-carbon steel;
HSS
Execution: lapped thread
to M 26
Thread: right-hand, left-hand

Werkstoff: WS-Werkzeugstahl;
HSS
Ausführung: geläpftes
Gewinde bis M 26
Gewinde: rechts, links

Материал: NO-инструментальная сталь; HSS
Изготовлено: резьба шлифованная до M 26
Резьба: правая, левая